

Multiple Disc Brakes FOB-6D

BALLEGGI
OLEODINAMICA

Features

- Large wheel mount brakes, motor input
- Sintered bronze friction plates
- Hardened high strength steel shafts
- Minimal brake torque 700 N-m (6200 lb-in)
- Operating pressure 350 bar (5080 psi)
- Release pressure 8 bar (116 psi), ideal for closed loop hydrostatic systems

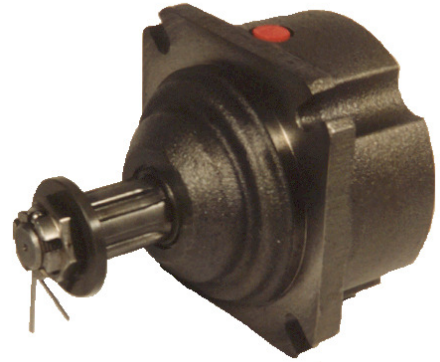

Technical Drawing

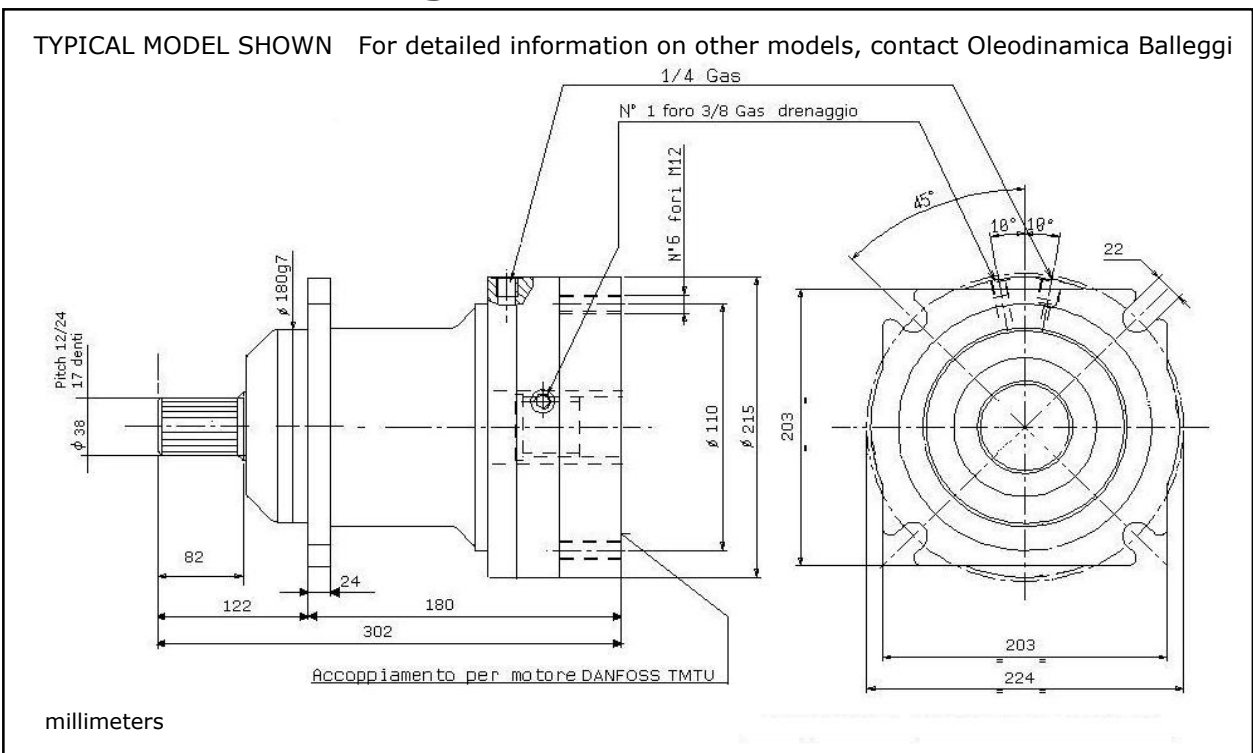

Specifications

Torque range at 0 bar (0 psi) back pressure.....160-700 Nm (1420-6200 lb-in)
 Release pressure range..... 9-31 bar (131-450 psi)
 Maximum operating pressure..... 350 bar (5080 psi)
 Maximum speed..... 3000 rpm
 Volume of oil to release brake (minimum)..... 4 cm³ (0.244 in³)
 (maximum)..... 8 cm³ (0.488 in³)
 Maximum operating temperature..... 110°C (230°F)
 Weight..... 15Kg (33.1 lb)
 Fluid type..... Mineral base hydraulic oil
 Direct wheel clamping

Oleodinamica Balleggi S.a.s. di Balleggi L. & C.
 Via Curtatone 3 - 20019 Settimo Milanese MI
 Tel.: + 39.02.48.92.06.84 / 02.48.92.63.51 Fax.: + 39.02.47.99.48.67
 E-mail: info@oleodinamica-balleggi.com; URL.: www.oleodinamica-balleggi.com